

John T. Conway, Chairman
A.J. Eggenberger, Vice Chairman
John W. Crawford, Jr.
Joseph J. DiNunno
Herbert John Cecll Kouts

DEFENSE NUCLEAR FACILITIES SAFETY BOARD

625 Indiana Avenue, NW, Suite 700, Washington, D.C. 20004
(202) 208-6400



April 19, 1995

Mr. Mark Whitaker, EH-9
U.S. Department of Energy
1000 Independence Avenue, SW
Washington, D.C. 20585

Dear Mr. Whitaker:

Enclosed for your information and distribution are eight Defense Nuclear Facilities Safety Board staff reports. The reports have been placed in our Public Reading Room.

Sincerely,

A handwritten signature in black ink, appearing to read "G. W. Cunningham".

George W. Cunningham
Technical Director

Enclosures (8)

DEFENSE NUCLEAR FACILITIES SAFETY BOARD

April 8, 1994

MEMORANDUM FOR: G. W. Cunningham, Technical Director

COPIES: Board Members

FROM: Ajit Gwal

SUBJECT: Report of Trip to Old HB-Line - Rooms 302, 304 & 306

1. **Purpose:** This memorandum reports the observations of DNFSB staff member Ajit Gwal during a visit to the Savannah River Site on March 17, 1994, to review the ventilation and fire protection systems in Rooms 302, 304 and 306 of the Old HB-Line.
2. **Summary:** The following major issues and observations were identified:
 - a. An air flow reversal event, similar to the airborne contamination event that occurred in October 1993, will occur upon loss of normal power and the 292-H diesel.
 - b. Room 304 contains a sufficient amount of combustible materials to create a severe fire hazard. The room contains no fire detection devices. Also, if a fire in room 304 is sufficiently intense, there is the possibility of its propagating to the adjacent room 302, with possible melting of the 16 gauge ventilation duct, and resulting in an air flow reversal and airborne contamination.
 - c. Radiological Controlled Area (RCA) signs, stating that airborne contamination exists beyond the doors, are posted on the two doors of room 304 which open to the west corridor. Both doors have open holes and long cracks. During loss of ventilation, air flow reversal could occur, and airborne contamination could expose the workers.
3. **Background:** Mr. Dan Burnfield of the DNFSB staff had previously reviewed radiological work practices in rooms 302, 304, and 306 of the old HB-Line and requested the review of the fire protection and ventilation system reported herein.
4. **Discussion/Observations:** DNFSB staff observations and findings from this review are as follows:
 - a. Ventilation and power outage scenario:
 - Loss of normal power and 254-5H#1 diesel (see Attachment 1).
 - Loss of normal power and 254-5H#2 diesel (see Attachment 2).
 - Loss of normal power and 221-H diesel (see Attachment 3).
 - Loss of normal power and 292-H diesel (see Attachment 4).
 - 221-H ventilation system normal operation (see Attachment 5).

The electrical feed configurations of supply and exhaust fans for these scenarios are presented schematically in Attachments 1 through 4. Attachment 5 provides the configuration for the normal operation of the ventilation system. Air reversal will not occur in scenarios 1 through 3. However, scenario 4 will lead to air flow reversal in room 306. It is anticipated that the Department of Energy (DOE) will evaluate this scenario and provide timely corrective action.

- b. Fire protection: There are no fire detection devices in room 304, which contains sufficient combustible materials to create a severe fire hazard. Room 304 is not continuously occupied. The staff believes it would be prudent to have a fire detection system with an alarm in the control room and to start roving fire watches at suitable intervals of time, to detect and suppress any fire.

A severe fire in room 304 has the possibility of propagating through a drywall to the adjacent room 302, which contains the exhaust ventilation duct for room 306 (Attachment 6). Under such conditions there is a possibility that the 16-gauge exhaust duct material in room 306 could melt during a fire and this could result in an air reversal and airborne contamination.

- c. Airborne contamination: RCA signs are posted on the two doors of room 304, which opens in the west corridor. The sign states that airborne contamination exists beyond the doors. It was noted, however, that these doors have open holes and long cracks. During normal operation, air flows from room 304 to the west corridor, ordinarily this does not pose any safety concerns for the workers present in room 304. However, during loss of ventilation, air flow reversal could occur and airborne contamination could expose the workers.

5. Future Staff Actions: The DNFSB staff intends to conduct follow-up reviews of the technical concerns identified in this memo to determine what actions are taken by DOE to:

- a. Evaluate and implement the corrective action to prevent any air flow reversal in room 306 due to loss of normal power and 292-H diesel.
- b. Evaluate and implement the corrective action to install a fire detection system and to start fire watches.
- c. Evaluate and implement the corrective action to prevent the exposure of workers to the airborne contamination due to existing holes and cracks in the doors of room 306.

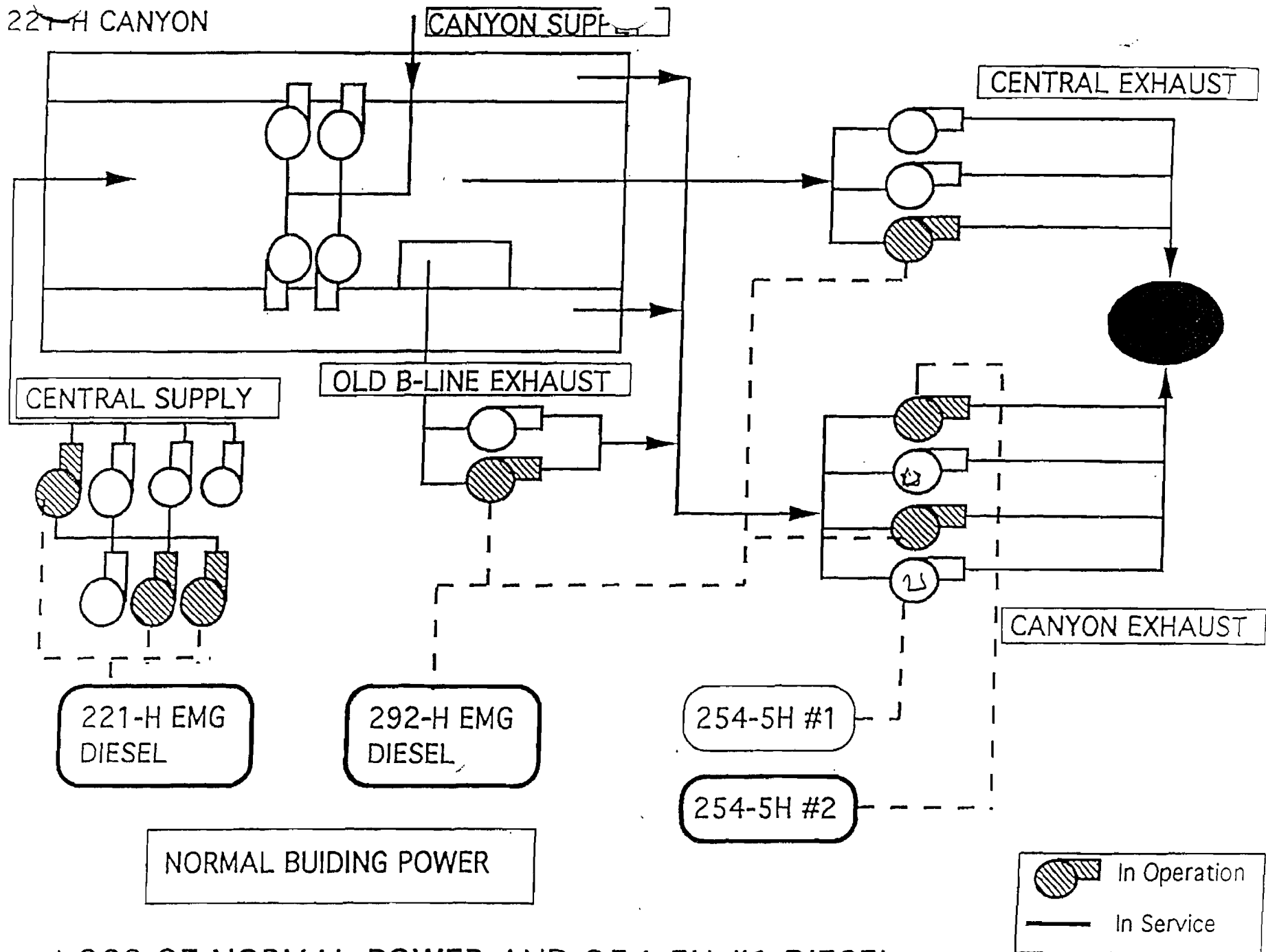

LOSS OF NORMAL POWER AND 254-5H #1 DIESEL

ATTACHMENT 1

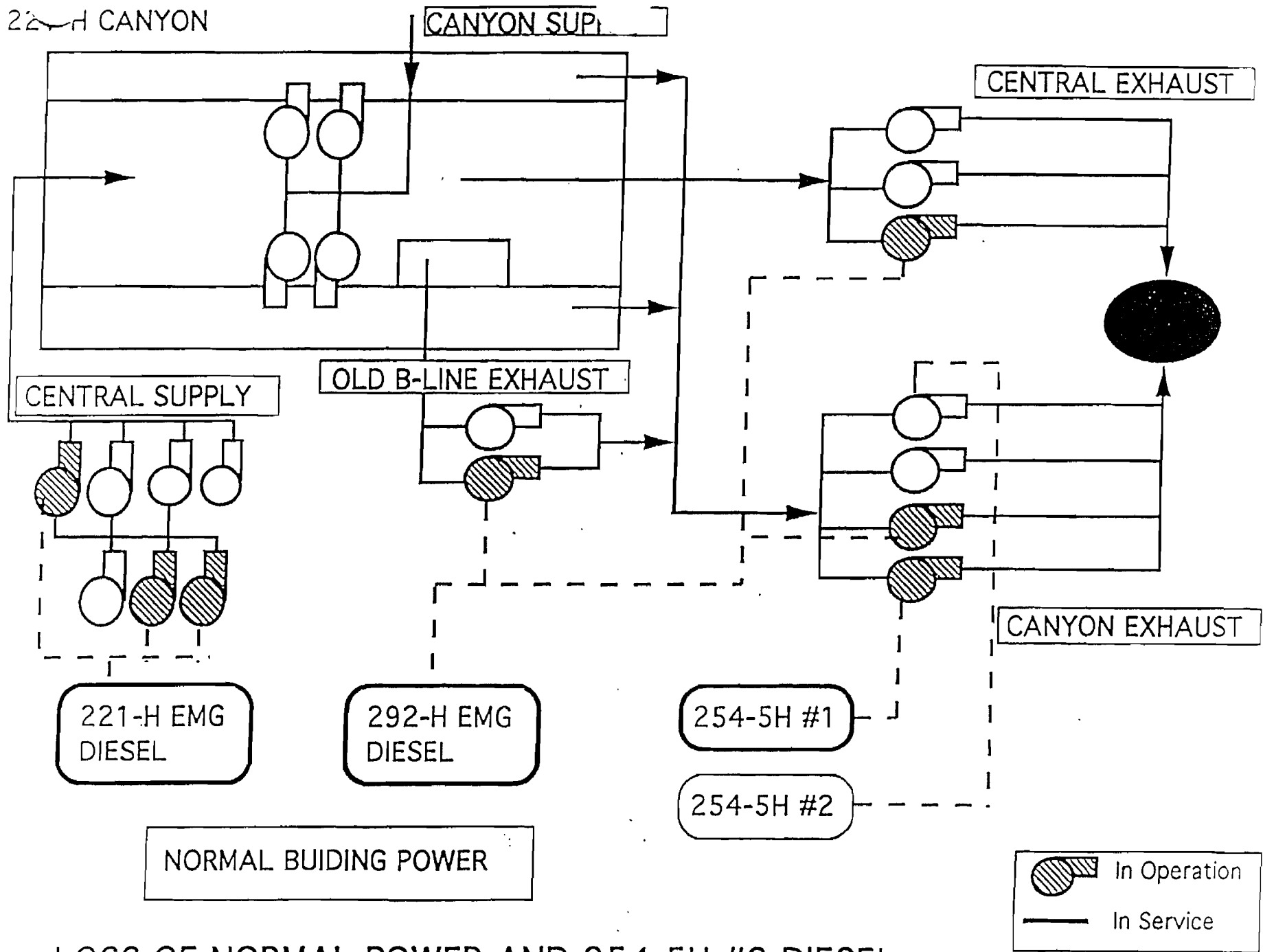

LOSS OF NORMAL POWER AND 254-5H #2 DIESEL

ATTACHMENT 2

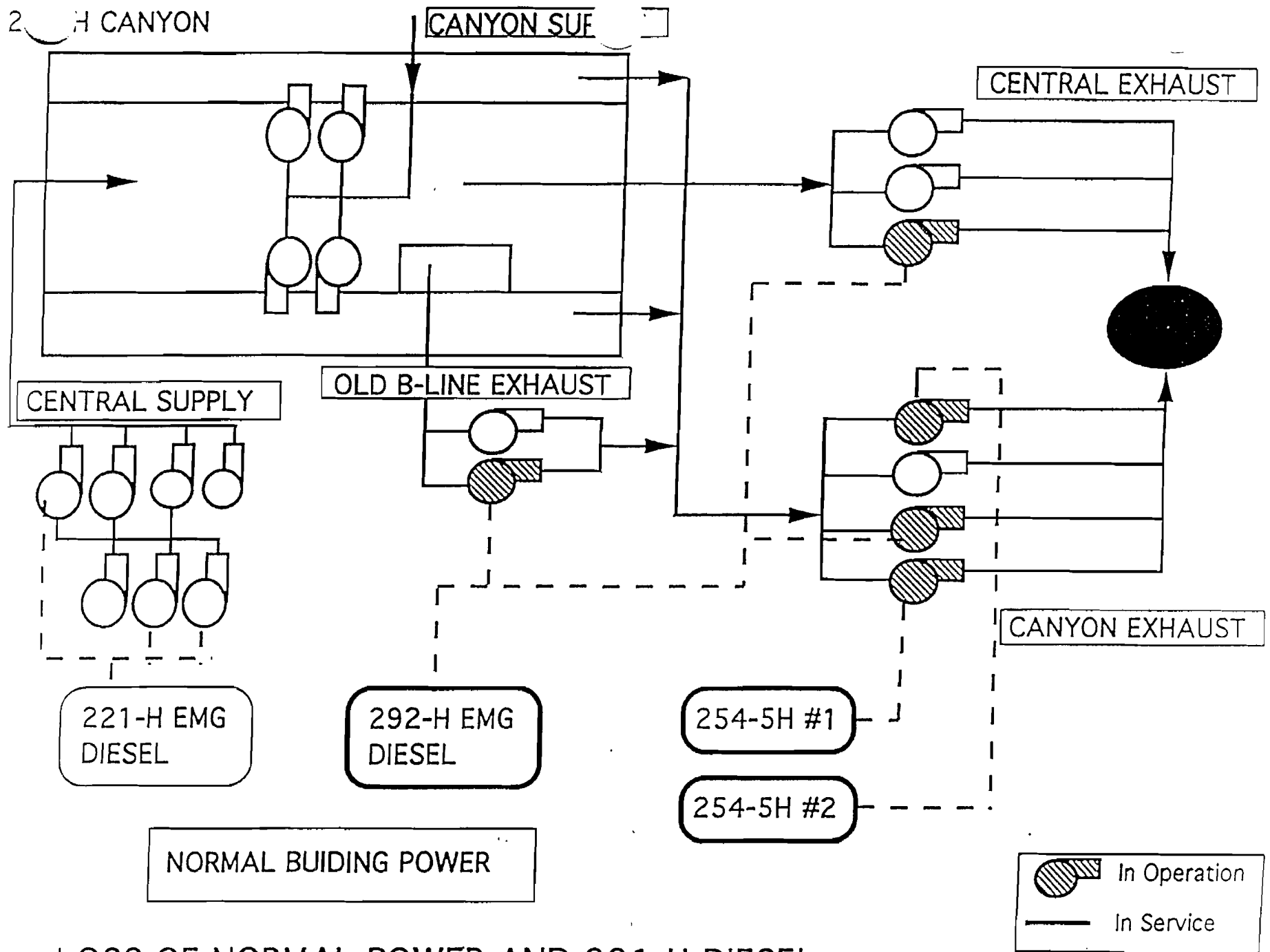

LOSS OF NORMAL POWER AND 221-H DIESEL

ATTACHMENT 3

22-H CANYON

CANYON SUP.

*AIR REVERSAL WILL OCCUR IN THIS SCENARIO

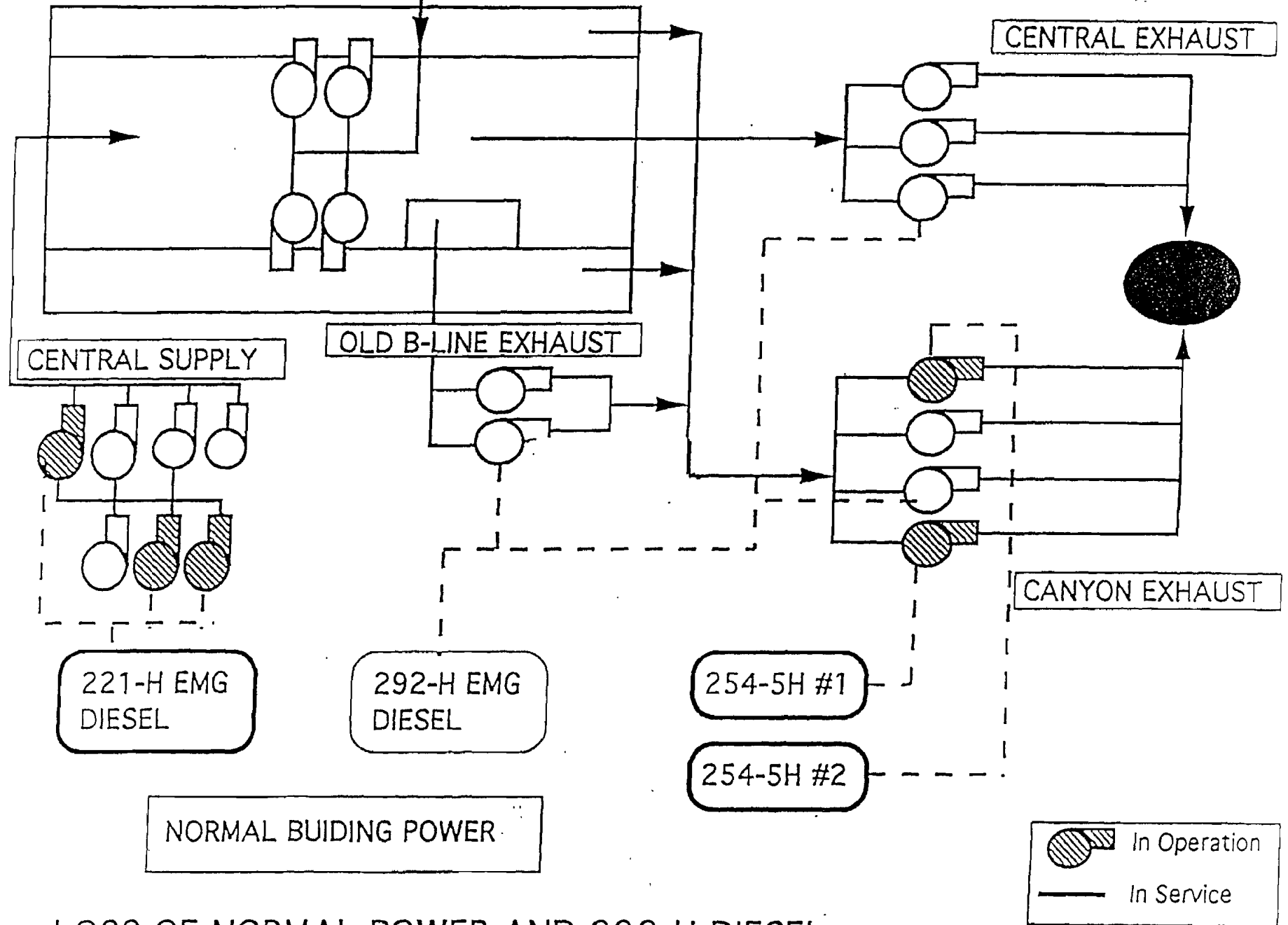

LOSS OF NORMAL POWER AND 292-H DIESEL

A T E A C H E T A A

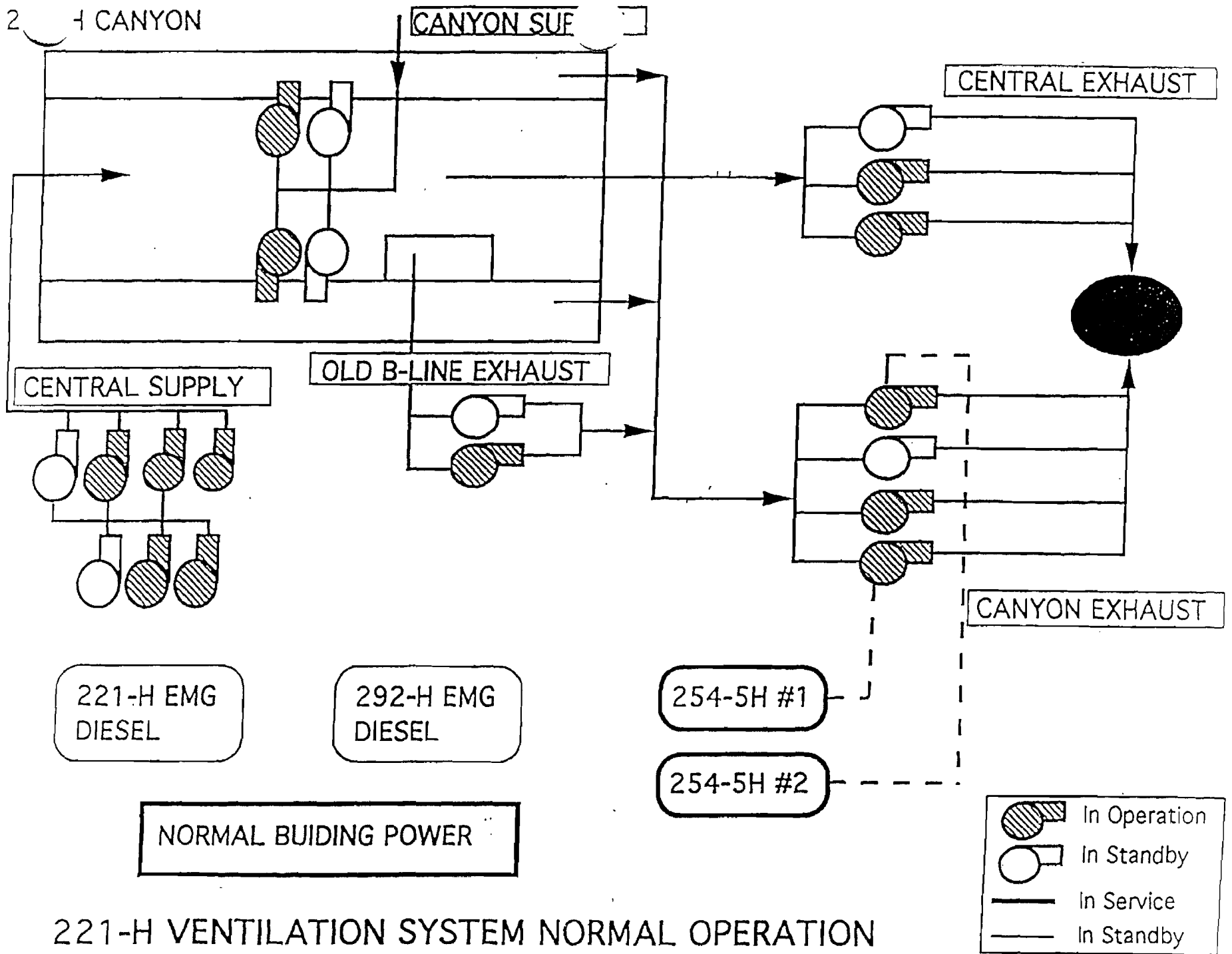

221-H VENTILATION SYSTEM NORMAL OPERATION

ATTACHMENT 5

ATTACHMENT 6

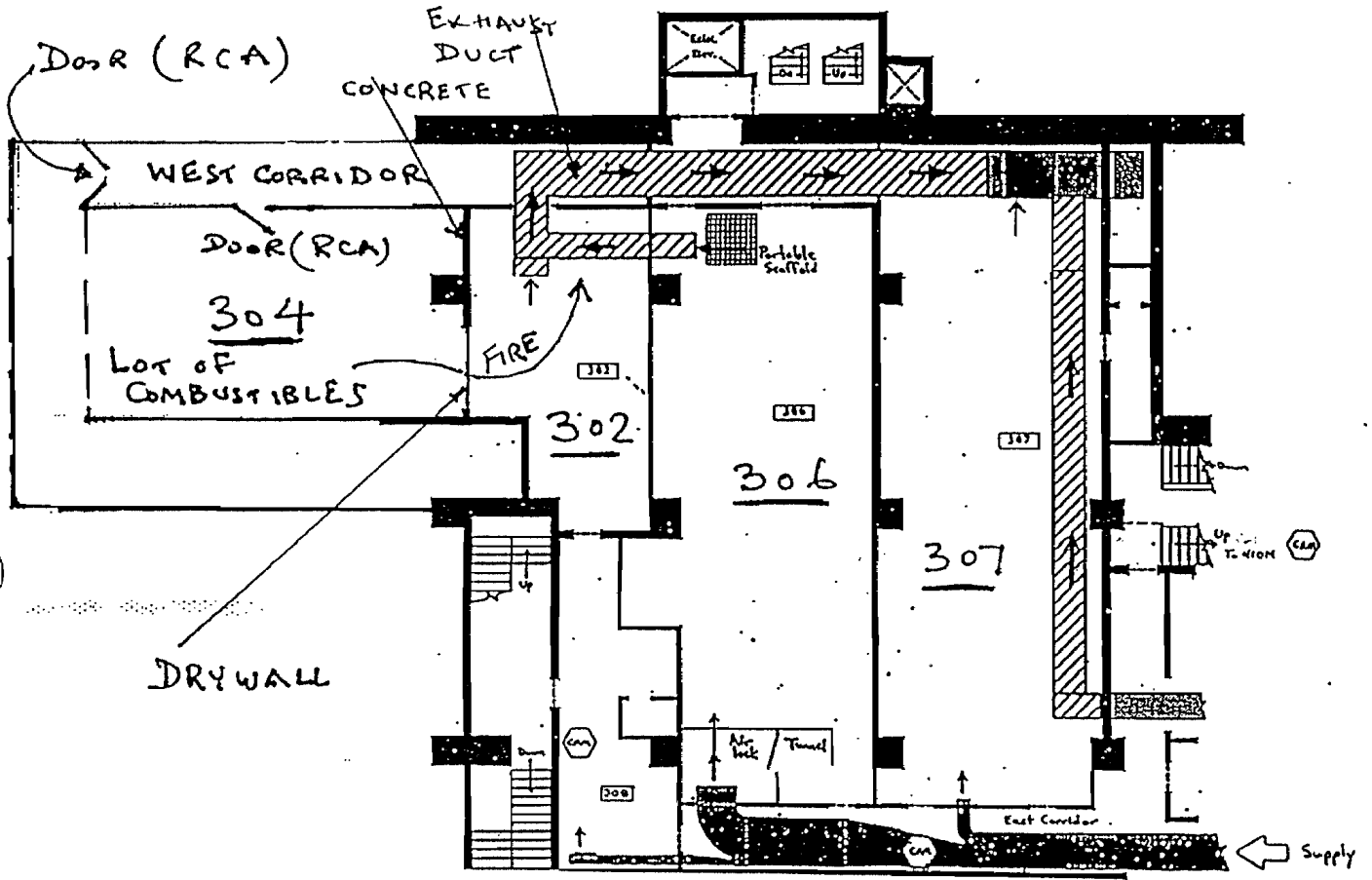

OLD HB-LINE